

## *UPS Operating Modes: A Global Standard*

---

## Executive Summary

UPS terminology is a complex subject, often made more confusing by the competing marketing claims of various manufacturers. This can make it difficult for specifiers and owners to understand and evaluate the options provided by competing vendors. The North American industry should consider the approach and terminology developed by the IEC. The IEC has defined UPS types based on the relationships and dependencies (or lack thereof) between input and output voltage and frequency. This paper explains these terms and discusses the capabilities and limitations of the various classifications.

## Areas of confusion

There are two areas where confusion seems to be most prevalent:

1. The meaning of the terms “on-line” and “conversion” when describing a UPS topology.
2. The power conditioning capabilities of “energy saver” or “Eco” modes of operation.

The primary motivation for clarifying this terminology is to make sure that the specified solution is actually capable of addressing the problems that it is intended to solve or prevent. For example, the terms “on-line” and “conversion” (as in “double conversion”) were historically used to describe and identify a UPS that converted incoming AC to DC and then back to AC, eliminating the largest range of power problems in the process. It was unusual for a manufacturer to highlight the fact that their UPS might be “single conversion” as this was considered to be a lower standard of performance, particularly in large three-phase application.

With the growing focus on energy efficiency, users have been demanding and manufacturers have been offering energy saver or “Eco” modes as a way to reduce energy consumption. These have gained acceptance as server power supply units (PSU’s) have evolved with wider tolerances for input voltage levels and longer ride-through capability, as measured by the ITI (formerly CBEMA) curve. The confusion arises as to the effectiveness of these modes in providing clean power to the critical load and controlling issues that could be reflected back to the source, including input current harmonics and load power factor issues.

These are issues which the new power supply designs do not always solve and in some cases will exacerbate.

In broad terms, there are two possible modes that can be considered “high efficiency”:

1. The load will be supported through the UPS bypass with NO interaction with the incoming mains (other than battery charging). This is typically referred to as an “off-line” or “standby” topology or mode;
2. The load can also be supported through the UPS bypass but the inverter can provide some level of power conditioning (and this can range from basic voltage regulation to active filtering of load-generated harmonics); This range of capabilities is typically referred to as “line interactive” topology or mode.

It is important to understand exactly which mode is offered and how that is controlled so that the specifier and user’s expectations and requirements are properly met.

As a starting point, it may be useful to review the range of common power issues and the traditional solutions which have been offered.

### Available solutions

There are several solutions presently available in the market to condition and improve the energy supply quality to the load:

- UPS
- Transient Voltage Surge Suppressor (TVSS)
- Static transfer switches
- Series active filters
- Parallel active filters
- Hybrid active filters (series and parallel)

The electrical supply quality depends on several types of disturbances that can be briefly summarized in the following categories:

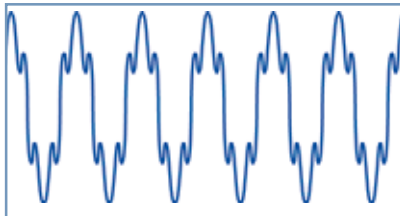

Harmonics and inter-harmonics

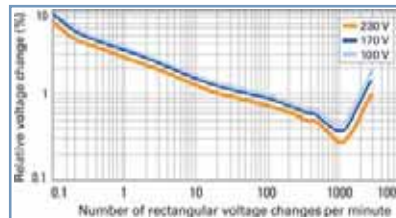

Voltage fluctuations and flickers

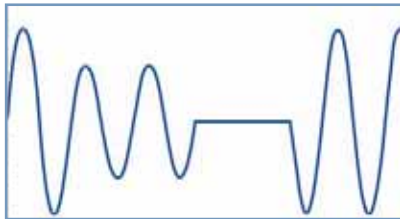

Voltage dip (sag) and interruptions

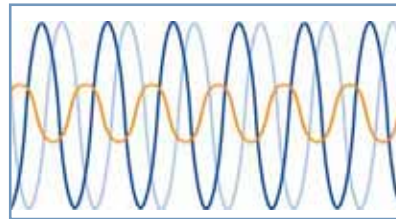

Voltage imbalance

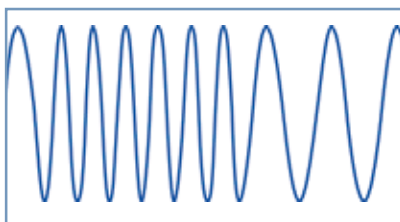

Power frequency variations

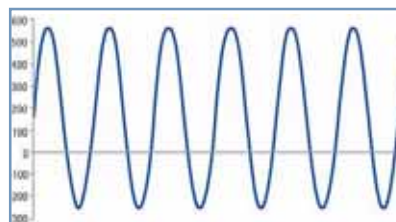

DC components

Other disturbances include , notching, electric noise, and inducted low frequency voltage and oscillatory transients.

### Typical electrical disturbances

The latter three solutions based on active filters are typically used to compensate all of the disturbance categories, except voltage interruptions and frequency variations, within certain limits and with high efficiency.

When considering the common electrical disturbances seen earlier on page 2, the UPS in its double conversion configuration, is the only one to date capable of compensating for all of the possible electrical disturbances.

The UPS is indeed capable of supplying high quality voltage to the load both during the presence of large voltage amplitude fluctuations and also during total power supply interruptions. The latter can be achieved with local energy storage devices, such as batteries or flywheels.

The double conversion UPS is certainly a leading solution, its only drawback is that it consumes a higher amount of energy in continuously converting input AC power to DC power and then back to AC for output to the loads.

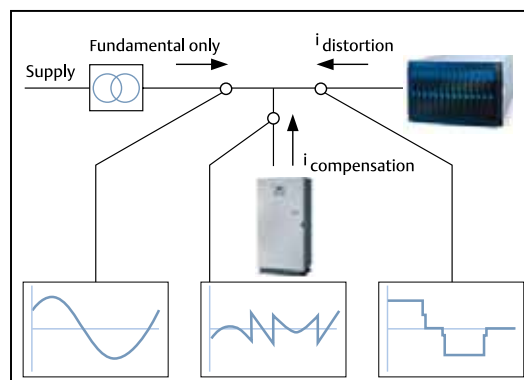

**Figure 1. Parallel active filter for harmonics, PF, and transient compensation.**

## Operating modes defined by IEC 602040-3

How the IEC definitions bring clarity. The IEC has identified three UPS topologies in its standard #62040-3. These are defined by the relationships and dependencies (or lack thereof) between input and output voltage and frequency characteristics.

- a). VFI—Voltage and Frequency of the Output are Independent of Input Voltage and Frequency—this is only possible if they are generated independently, as in a double conversion mode or topology.
- b). VFD—Voltage and Frequency of the Output are Dependent on the Input. This is true if there is no voltage regulation or independent generation of the output, which identifies a standby or offline mode. There can be some passive filtering, but no active power correction.
- c). VI—Voltage of the Output is Independent of Input (Frequency In = Out). This is descriptive of line interactive mode or topology

All of these are predicated on the ability of the UPS to maintain these relationships within a specified range without resorting to battery power. By defining these relationships in this way, the focus is on WHAT the UPS actually does (and therefore, what problems it can address) as opposed to HOW it actually achieves the result.

Thus, competing methods of achieving these results can be evaluated by the specifier or end user, knowing that they are actually comparing apples to apples.

VFI operation

IEC 62040-3 VFI is the double conversion mode which provides the highest level of power conditioning. It protects the load from all types of electrical network disturbances using a greater amount of energy. Efficiency at full load with the latest transformer-free technology is over 94%.

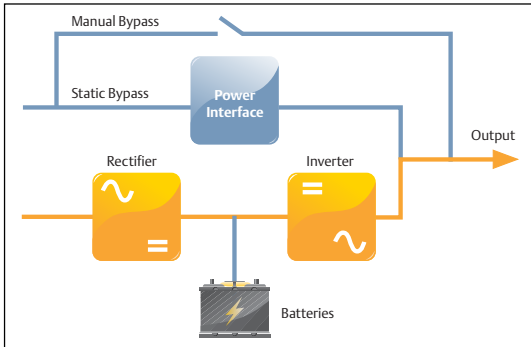

**Figure 2. New transformer-free VFI UPS (double conversion)**

VFD operation

This mode may be used when the need for conditioning is non-existent and allows energy flow to pass through the bypass line. In this case efficiency reaches 99%.

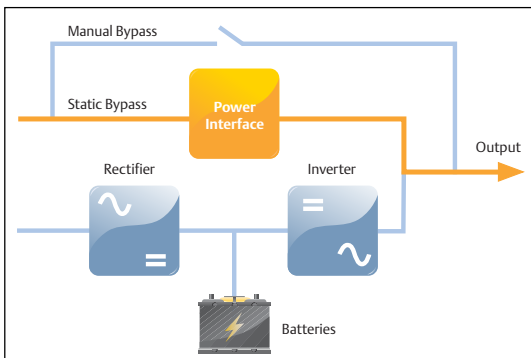

**Figure 3. New transformer-free VFD UPS**

VI operation

IEC 62040-3 VI compensates only the main disturbances such as mains sags and swells. In enhanced mode, this can also address issues such as load THDi and load PF. The energy used is derived from the use of the inverter as an active filter giving all the necessary reactive power. In a typical condition this mode will have an efficiency of between 96 and 98%, depending on the load type (e.g. non-linear, linear, etc.) and the input mains conditions.

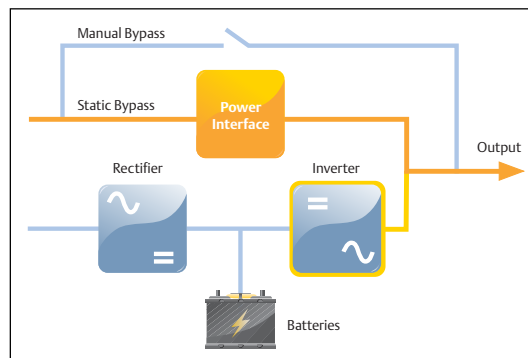
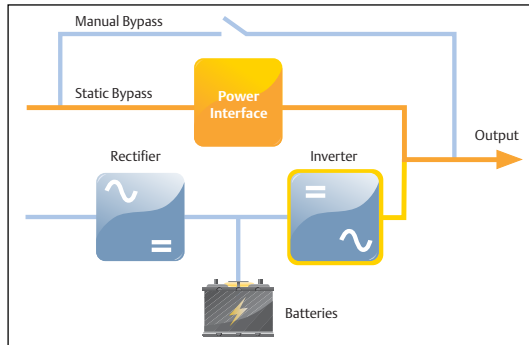

**Figure 4. New transformer-free VI UPS with active filter compensating the mains or load disturbances.**

## Using the inverter as an active filter

An enhanced version of a VI UPS allows compensation of most of the disturbance categories seen on page 2, except voltage interruptions and frequency variations, within certain limits while continuing to maintain a high efficiency. This can be achieved given that the active filter uses less power than double conversion to compensate disturbances.

The good news, in this case, is that the active filter does not need to be an extra, bulky component added to the UPS since an IGBT inverter controlled by appropriate technology can function as an active filter. This is possible, because the inverter itself is idle when the UPS is in high efficiency mode, making it possible to use the inverter both in series and parallel.



**Figure 5. Enhanced VI UPS technology. The UPS is configured to automatically compensate some disturbances on the network by using the IGBT inverter as an active filter that can be both configured as a parallel or series active filter, while the load is supplied through the static bypass line.**

**Inverter as a parallel active filter:**  
the inverter will work as a current controlled generator, generating a current that compensates the reactive and harmonic content of the load.

**Inverter as a series active filter:**

the current of the active filter will have a shape intended to compensate the bypass line voltage in order to be able to remain inside the tolerance limits. This is possible by adding a series inductance that adds a small line impedance for the active voltage compensation by interacting with the current of the active filter generated by the inverter.

Proportional to the current generated for the compensation of disturbances, power losses will be greater than those experienced on the high efficiency bypass line, but in any case will be less than those which occur in the double conversion mode.

If this is then incorporated with the use of the latest transformer free technology in the same UPS, it becomes evident that this UPS offers the highest possible efficiency while maintaining tight standards of power quality.

## **Conclusion**

The definitions developed by the IEC to identify the various operating modes (or topologies) of UPS's can eliminate much of the confusion emanating from various manufacturers' terms and feature brand names, enabling the specifier and user to make better informed choices. These definitions provide objective benchmarks for comparing the expected power quality performance of competing offerings in high efficiency operating modes. As energy efficiency becomes more and more critical, the specifier and customer will be better able to understand and select the best solution for their applications.

## **Emerson Network Power**

1050 Dearborn Drive  
P.O. Box 29186  
Columbus, Ohio 43229  
800.877.9222 (U.S. & Canada Only)  
614.888.0246 (Outside U.S.)  
Fax: 614.841.6022  
EmersonNetworkPower.com  
Liebert.com

While every precaution has been taken to ensure accuracy and completeness in this literature, Liebert Corporation assumes no responsibility, and disclaims all liability for damages resulting from use of this information or for any errors or omissions.

© 2010 Liebert Corporation. All rights reserved throughout the world. Specifications subject to change without notice.

All names referred to are trademarks or registered trademarks of their respective owners.

©Liebert and the Liebert logo are registered trademarks of the Liebert Corporation. Business-Critical Continuity, Emerson Network Power and the Emerson Network Power logo are trademarks and service marks of Emerson Electric Co. ©2010 Emerson Electric Co.

SL-24653-R10-10 Printed in USA

---

## **Emerson Network Power.**

The global leader in enabling Business-Critical Continuity™.

- |                |  |                              |                               |
|----------------|--|------------------------------|-------------------------------|
| ■ AC Power     | ■ Embedded Computing                     | ■ Outside Plant              | ■ Racks & Integrated Cabinets |
| ■ Connectivity | ■ Embedded Power                         | ■ Power Switching & Controls | ■ Services                    |
| ■ DC Power     | ■ Infrastructure Management & Monitoring | ■ Precision Cooling          | ■ Surge Protection            |

## **EmersonNetworkPower.com**