

Adding another vital layer of security to mission critical applications



All too often people wrongly assume that simply installing a UPS will be the end of their problems. However if the design and installation are handled badly it could be just the beginning.

UPS systems must be fault tolerant and maintainable, while the critical load must remain supported and fully operational. The objective should be for a system that allows any single part to fail and be repaired and tested without affecting the operation of the critical load. Reliability of distribution to the final load is vital to the continuous availability of power systems. System failures are often caused by problems in the distribution system not by failures of the power source itself. Using static switches can make significant improvements in the reliability of the power supply to mission critical equipment.

Whilst a traditional UPS protects the load and improves the quality of the power source, it cannot ensure the elimination of problems that can occur downstream from the UPS such as overloads and short circuits.

Chloride has developed CROSS online static switches to satisfy two objectives: to increase the reliability of power sources and to eliminate the high percentage of faults linked to electrical distribution problems in the system downstream of the source.

How a static switch works

Static switches drive up the MTBF by eliminating the effects of failure in the distribution network and also allow UPS maintenance to be carried out without having to power down the load.

A static switch provides instant load switching from one power source to another and, when combined with a UPS, offers two fold redundancies. When the power supply feeding the load begins to operate outside accepted limits it immediately switches the load to an alternative supply implementing automatic

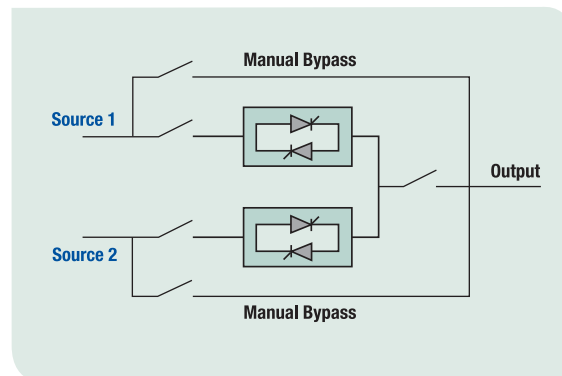

source switching to provide additional power protection downstream from the UPS. This is the final link in the distribution system and is achieved by using at least two completely independent power sources. The static switch supplies the critical load using one of the two completely independent power sources and if the active source develops a fault or its electrical features are no longer suitable, will transfer the load to the alternative sources. Switching is controlled in such a way as to guarantee transfer times are completely compatible with the load tolerance and in accordance with the technical standards in force.

Break before make (BBM) technology

When considering the use of this equipment it is essential to remember that the transfer must always take place in such a way that the potentially dangerous passage of current between the sources is prevented. A crucial function is the 'break before make' transfer which ensures that the two live feeds are never connected in

parallel. It also ensures that switching between the two power supplies occurs under both synchronous and asynchronous conditions relative to the input waveforms. This feature ensures that the CROSS system is radically different to other systems since it guarantees BBM in any condition with any type of load.

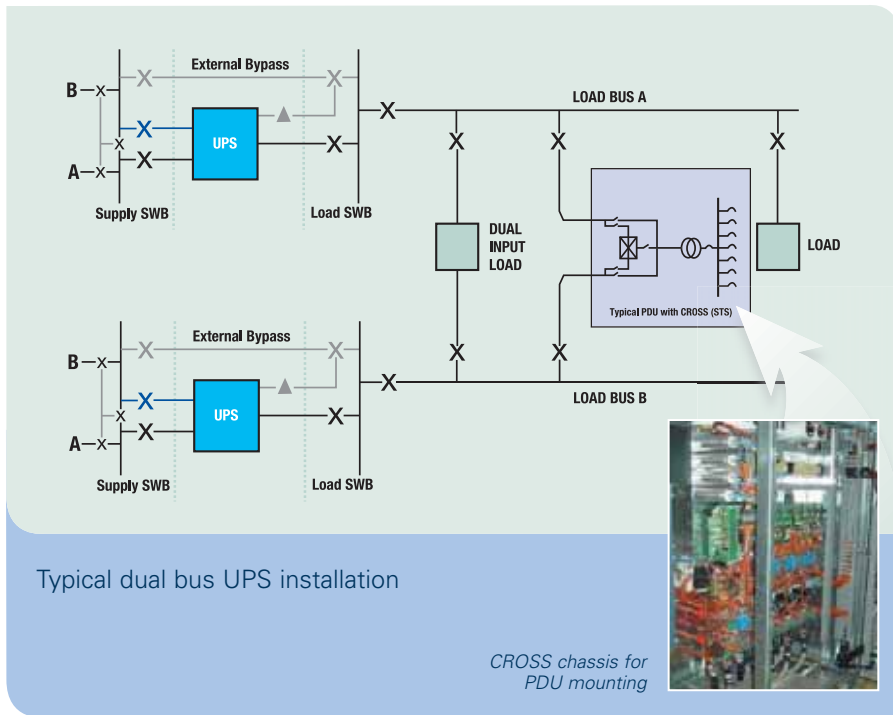

About the author

Rob Tanzer
BSc

Rob Tanzer is Technical Support Manager for Chloride Power Protection. He has worked in the UPS industry for over 30 years and has experience and knowledge of most of the different types of static and rotary UPS systems currently in service today.

Rob is the author of several published technical papers covering UPS systems, thyristor power switching devices and different aspects of UPS systems applications.



Examples of where this technology has been used include Allianz Cornhill Insurance who recently replaced its existing UPS unit with two Chloride 400kVA UPS systems, a dual feed supply and two replacement PDU's, each supported by two to two 600A CROSS static switches. Fifty-five server cabinets were also equipped with smaller CROSS rack mounted static switches to enable a no-break transfer between the two supplies.

Replacing the power distribution system involved fitting each of the two PDU's with a set of six 250A busbars with tapping boxes. This configuration provided dual redundancy so should either PDU go down the connected cabinets are still powered up. By installing the rack mounted switches in bespoke cabinet top enclosure stands between the tapping boxes and the cabinet, problems associated with tripping are overcome. Whilst it is normal to install the 2U rack static switches within the cabinet, this bespoke arrangement facilitates easy access without disruption to the cabinets.

Chloride UPS systems and CROSS static switches have also been installed at Cathcart, one of the main SCADA Electrical Control Rooms critical to the functioning of the rail network in the West of Scotland.

Situated in the main electrical control room they ensure a no break electrical supply for its critical electrical supply facilities.

The installed system places separate 10kVA UPS on two incoming supplies and the static switches on each essential distribution board to assure the continuity of the power supply at all times, even in the event of one of the two REC supplies failing.

The selection of static transfer switch technology should be driven by the importance/cost of the supported load and the need for system resilience and maximum availability of power to that load.

For more information please visit our website
www.chloridepower.com

Chloride is an international provider of secure power solutions for business continuity for customers worldwide. Our innovative solutions and services protect business critical systems and processes from the damaging effects of poor quality electrical power and power interruptions.