

ONEAC Sinergy® Series UPS (700 - 3000 VA)

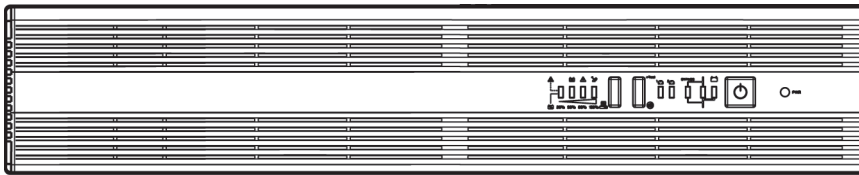

- S0K7XAU
- S1K0XAU
- S1K5XAU
- SBP1K5-2
- SBP3K0-2
- S2K0XAU
- S3K0XAU
- S2K0XHU
- S3K0XHU

CHLORIDE

Sinergy[®] S II Series User Instruction Manual

IMPORTANT SAFETY INSTRUCTIONS

SAVE THESE INSTRUCTIONS.

Please read and save these instructions. This manual contains important instructions for ONEAC models:

- S0K7XAU
- S1K0XAU
- S1K5XAU
- SBP1K5-2
- SBP3K0-2
- S2K0XAU
- S3K0XAU
- S2K0XHU
- S3K0XHU

Please read and save these instructions. This manual contains important instructions for this UPS and External Battery Cabinet. Follow these instructions during the unpacking, installation, and maintenance of the UPS and the external battery cabinet. If you have a problem with the UPS or the battery, please refer to this manual before calling technical services.

Chloride
27944 North Bradley Road
Libertyville, IL 60048-9700
USA

Telephone: (847) 816-6000
Toll Free: (800) 327-8801
Fax: (847) 680-5124

www.chloridepower.com/usa

Licenses and Trademarks

ONEAC, Sinergy, ManageUPS and MopUPS are all registered trade marks of ONEAC. All other trademarks, product and corporate names are the property of their respective owners.

Entire contents copyright © 2010 Chloride. All rights reserved. Reproduction in whole or in part without permission is prohibited. All information subject to change without notice.

Introduction	1
Registering Your ONEAC UPS	1
Technical Support	1
FCC Compliance	1
Safety Compliance	1
About This Manual	1
Safety	2
Intended Use	2
General Warnings	2
Safety Notices	2
Battery Safety	3
Repacking of Unit	3
Setup	4
Delivery	4
Unpacking	4
Storage	5
Environmental Conditions	5
Floor Loading	5
Ventilation	5
Installation	5
Rack-Mounting the UPS or External Battery Cabinets	6
Tower (Floor) Mounting and External Battery Cabinets	7
Electrical preparations	8
Connections	8
Theory of Operation	9
UPS Mode	9
Battery Mode	9
Bypass Mode	10
Front Panel Display and Control	10
System Indicators	11
Rear Panel	12
UPS Start-up & Shutdown	14
Normal UPS Start-up Procedure	14
Manual Bypass Procedure	14
UPS Shutdown Procedure	14
Remote Power Off (RPO)	14
Maintenance	15
UPS Storage	15
Battery Testing	15
Replacing Batteries	15
Battery Disposal	17
Interfaces	17
Serial interface COM 3	17
Interface Slot COM	17
Communications	17
Optional Isolated Contacts Card	18
Troubleshooting	20
Warranty	21
Batteries	21
Limitations of Warranty	21
Exclusive Remedies	21
Return Procedure	21
Appendix A: Features and Specifications	22
Physical and Electrical Specifications	23
Specifications	24

Introduction

Thank you for selecting this uninterruptible power supply (UPS). ONEAC's Sinergy S II Series UPS offers the most reliable protection from the harmful effects of electrical line disturbances for your computing and communications equipment. ONEAC's ISO 9001 certification represents our commitment to building world-class products. We take pride in every unit that leaves our manufacturing facility.

Registering Your ONEAC UPS

To ensure that your Sinergy S II Series UPS model and serial number are registered, complete and mail the enclosed postage-paid warranty card or go on line at www.chloridepower.com/usa.

Technical Support

Chloride offers 24-hour technical support. To contact Technical Services:

- North America: toll free (800) 327-8801 (opt 3), local (847) 816-6000 (opt 3)
- email: us.service@chloridepower.com

Please check with technical services before attempting to repair or return any ONEAC product. If an ONEAC product needs repair or replacement, Technical Service issues a Return Material Authorization (RMA) number along with instructions on how to return the product.

FCC Compliance



ATTENTION: Changes or modifications to this unit not expressly approved by the party responsible or in FCC compliance could void the user's authority to operate the equipment.

The 2-3 kVA models have been tested and comply with the limits for a Class A digital device, pursuant to Part 15 of FCC Rules. These limits are designed to provide reasonable protection against harmful interference when the UPS is operating in a commercial environment. The UPS generates, uses, and can radiate radio frequency energy. If installation and use is not in accordance with the instruction manual, it may cause harmful interference to radio communications.



ATTENTION: Operation of this equipment in a residential area may cause harmful radio communications interference. The user is responsible for correcting the interference.

The 700 VA to 1500 VA models have been tested and comply with the limits for a Class B digital device, pursuant to Part 15 of FCC Rules. These limits are designed to provide reasonable protection against harmful interference when the UPS is operating in a residential environment. The UPS generates, uses, and can radiate radio frequency energy. If installation and use is not in accordance with the instruction manual, it may cause harmful interference to radio communications.

Safety Compliance

UL/cUL listing to UL1778

TUV compliance to EN62040-1

CE

About This Manual

This manual contains information regarding the installation, operation and use of the Uninterruptible Power Supply (UPS).

Consult this manual before installation of the equipment, which should be performed only by qualified personnel. This User's Manual should be kept for later reference for operation and maintenance of the UPS.

These instructions may be supplemented with additional sheets, describing specific extensions or options.

The following symbols are used in this manual:



ATTENTION: Indicates instructions, which if not observed, may endanger reliability of your UPS or the security of your data.



WARNING: Indicates instructions, which if not observed, present risk of electric shock, may endanger your life, your health, reliability of your UPS or the security of your data.

Safety Intended Use

- This device serves as an uninterruptible power supply for connected loads. The device is in compliance with all relevant safety regulations concerning information technology equipment, for use in an office environment.
- Depending on the type and rating of UPS device, certain configurations of battery extensions may be connected. These battery extensions may only be connected to the compatible basic UPS unit.

General Warnings



WARNING: We consider the safety of personnel to be of paramount importance. For this reason it is essential that procedures relating to safety in this manual be carefully reviewed before commencing work, and properly adhered to thereafter. The User or Operator may intervene in the operation of the UPS provided that the instructions laid out in the section titled “Installation” on page 5 are strictly followed.



WARNING: Even when all switches and/or circuit breakers are open, dangerous voltages are present within this unit! There are no user-serviceable parts inside. Only factory authorized technical personnel may carry out any operation that requires protection panels to be opened and/or removed. Any repairs or modifications by the user may result in out-of-warranty repair charges, unsafe electrical conditions, or violation of electrical codes.

Safety Notices



WARNING: Read the following safety notices carefully! Disregard of these safety notes may endanger your life, your health, and the reliability of your device and the security of your data.

- Transport the unit only in suitable packaging (protected against jolts and shocks).
- If the equipment is moved from a cold environment to a warmer operating location, condensation may occur. Before you switch on the equipment it must be absolutely dry. An acclimatization period of at least two hours is required.
- The equipment must be installed in accordance with the environmental conditions specified in “Environmental Conditions” and in Table 2.
- Even with all buttons in “OFF” position the device (UPS) is not isolated from the mains. To isolate completely from the mains, the power cord must be disconnected.
- This equipment services power from more than one source. The output terminals and/or receptacles may have voltage present even when the unit is unplugged. UPS’s present a different safety issue than most electrical equipment because unplugging the UPS puts it into backup mode. Unplugging the UPS does not remove the electrical charge.
- In case of interruption of the mains voltage, the integrated battery maintains the power supply to the user’s equipment.
- The power supply cord is intended to serve as the disconnection device. The outlet-socket must be near the equipment and must be easily accessible.
- This UPS must be connected to an earthed mains outlet-socket.
- Place all cords so that nobody can stand on them or trip over them. When connecting the device to the power supply, follow the instructions in the section titled “Installation”.
- Make sure that no objects (e.g. pins, necklaces, paper clips, etc.) get inside the device.
- In emergencies (e.g. damaged case, controls or power cables, penetration of liquids or foreign matter) switch off the device and contact Technical Support for assistance.
- Do not connect equipment that will overload the UPS or demand DC-current.
- When cleaning the unit, follow the instructions in the section titled “Maintenance”.
- Data transmission lines should not be connected or disconnected during a thunderstorm.
- Remote Power Off (RPO) is located on the rear of the unit (see Figure 11 and Figure 12). When this connection is open, the logic circuit will immediately shut down the UPS output.
- When installing units in racks do not allow racks to become “top heavy.” Install heaviest equipment (typically the UPS and batteries) near bottom of rack, and install this equipment before installing equipment higher in the rack.

Battery Safety



WARNING: The batteries installed in the UPS and within the battery extensions contain electrolyte. Under normal conditions the containers are dry. A damaged battery may leak electrolyte that can be dangerous in contact with the skin and cause irritation to the eyes. Should this happen wash the affected part with copious amounts of water and seek immediate medical advice.

- Voltage is always present on the battery terminals.
- Even when discharged, a battery has the capacity to supply a high short circuit current, which, in addition to causing damage to the battery itself and to associated cables, may expose the operator to the risk of burns.
- Batteries should not be kept in storage for periods exceeding 6 months at 25°C without being recharged (having been charged to 100% at the beginning of any such period). If these conditions are not respected the performance of the battery can no longer be guaranteed. It is advisable to recharge the batteries at least once every 4 months.
- Since new batteries often do not provide full capacity after an initial charge it may be necessary to carry out a number of discharge/recharge cycles before optimum performance is achieved.
- In order to protect the environment, batteries must be disposed of in accordance with the regulations governing disposal/recycling of toxic and harmful waste.

Repacking of Unit

Do not pack the equipment until at least two (2) hours have elapsed since the last recharge.

Place the equipment in bags made of a material sufficiently porous to allow it to breathe (e.g. 100µm polyethylene).

Do not remove air from the packaging.

When packing unit for movement by common carrier, place in original, or equivalent packaging container.

Setup Delivery

The equipment has been thoroughly checked before shipment. Upon receipt, check the packaging and ensure that the contents are undamaged. Any damage must be reported to the shipper and any missing parts must be reported to the supplier immediately.

Unpacking

Care should be taken when removing the packaging in order to avoid damaging the equipment. Check all packaging materials to ensure that no items are discarded. Remove the packaging following the sequence illustrated in Figures 1.



WARNING: This unit is heavy and requires two persons for safe lifting

Tools Required

- Scissors or knife
- Screwdriver

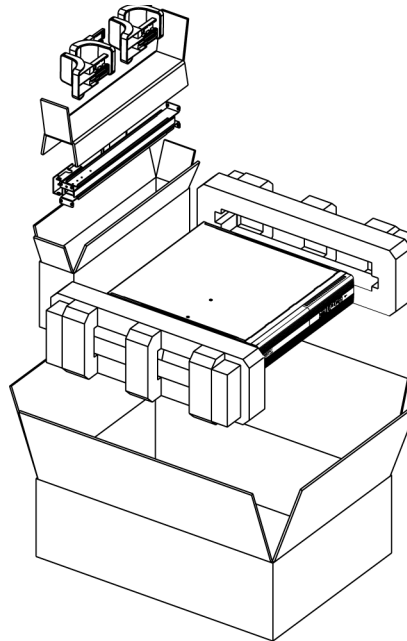

Fig. 1: Unpacking the UPS

This UPS includes:

- (1) UPS
- (1) USB Cable
- Mounting Hardware
- Tower Stands
- MopUPS Professional
- Manual

Additional items:

For high voltage models (models with XHU in the part number) also include:

- Cord Retention Bracket
- (1) IEC320 to IEC Extension Cords
- (1) IEC/NEMA Input Power Cord

Storage

If the UPS is to be stored prior to use, it should be stored in a clean, dry environment and away from temperature extremes. It is recommended that the equipment be stored in a temperature controlled, moderate humidity environment. Table 1 below provides the temperature and humidity storage limits:

Table 1. Storage Data

Temperature limits -Batteries ONLY	32°F to 104°F (0°C to +40°C)
Temperature limits - UPS without batteries	-13°F to 131°F (-25°C to +55°C)
Temperature limits – UPS with batteries	32°F to 104°F (0°C to +40°C)
Relative humidity (non-condensing)	0% to 90%

NOTE: When storing equipment, every 8°C above 25°C reduces the shelf life of the battery by 50%. More frequent battery charging is required to maintain the batteries in storage at these greater temperatures.

Environmental Conditions

The UPS must be installed on a level and even surface and in an area protected from extremes of temperature, water, humidity and the presence of conductive powder or dust (See Table 2 on page 5). Do not stack units and do not place any objects on top of a unit.

The functional temperature range of the UPS is 32°F to 104°F (0°C to 40°C).

The ideal ambient temperature range is 60°F to 77°F (15 °C to 25°C).

Expected battery runtimes and battery life is based on operational temperatures between 68°F and 77°F (20°C and 25°C). Operation of the equipment above 77°F (25°C) reduces the service life of the batteries dramatically.

Floor Loading

Taking into consideration the weight of the UPS, extension battery packs, and any other equipment that may be mounted in an associated rack, confirm that the floor in the chosen location be capable of supporting the weight of the combined units.

NOTE: Weights for the UPS and battery packs are shown in “Appendix A: Features and Specifications” on page 22”.

Ventilation

It is necessary to leave a minimum space of at least two inches (50 mm) in front and rear of the UPS to allow a flow of air.

Electrical maintenance and servicing requires access to the front and back of the UPS. Provide the necessary space to allow service personnel access to the UPS.

Installation



ATTENTION: This UPS is supplied with standard power cords and receptacles suitable for its use in your area of operation. It may be installed and operated by non-technical personnel..

Table 2 Installation Data

Item	Specification
Ambient temperature	32°F to 104°F (0 °C to 40C°)
Relative humidity (non condensing)	90%
Environment	Controlled (i.e. Office or equivalent)
Operating altitude (no derating)	3280 ft. above sea level (1000 m.a.s.l.)
Operating altitude (above 1000 m)	see Table 6 on page 25
Input Power Connection	Rear
Output Power Connection	Rear
Battery Power Connection	Rear
Air inlet	Front
Air outlet	Rear

Rack-Mounting the UPS or External Battery Cabinets

The UPSs and external battery are designed to be rack-mounted in four-post frames. The UPS and external battery cabinets use identical mounting hardware and the procedure for mounting either is the same.

NOTE: The Rack-mount UPS draws cooling air from the front. If the rack has a door on the front, make sure that there is some clearance between the vents and the rack door.

Because of the weight of these units, two people are recommended to lift and hold into position while all fasteners are secured. Please use only the supplied fasteners to attach the supplied mounting brackets to the UPS or external battery.

If external batteries are included in your installation, please mount them first and as low as possible. Start with the lowest available position and work up. Your UPS should be installed last and end up on the top of all the battery units for proper cable routing.



ATTENTION: Use all supplied mounting hardware on each UPS and external battery. NEVER depend on lower devices to support other devices.

All mounting materials are provided to install the UPS into a rack. To prepare the UPS and external batteries for use in a rack configuration, first install the included mounting rails, then install the UPS and batteries following the steps below.

1. Assemble side rails and secure each rail together with three screws.
2. Attach front of rails to front of rack with two screws provided.
3. Attach rear of rails to rear of rack with two screws provided.
4. Attach front brackets to each side of UPS with four screws on each side.
5. Slide UPS into position in the rack and secure with two screws on each side of UPS.
6. Repeat the above steps for each UPS or battery to be mounted.

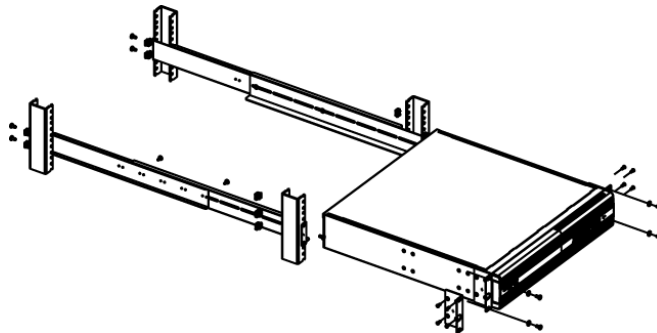

Fig. 2: Mounting the UPS in a Rack

After mechanical installation is complete, follow the instructions in “Connections” on page 8. Connect your UPS and external battery cabinets.

Tower (Floor) Mounting and External Battery Cabinets

The UPS and external battery are designed to be floor standing as an alternative to rack mounting.

⚠ ATTENTION: Use all supplied mounting hardware on each UPS and external battery.

Please use only the supplied fasteners to attach the supplied mounting brackets to the UPS or external battery. Each UPS and External Battery Cabinet requires four (4) screws provided.

After mechanical installation is complete follow the instructions in the section titled “Connections” on page 8 to connect your UPS and external battery.

Mounting the Tower UPS Only

1. Assemble the two sets of feet included with the UPS,

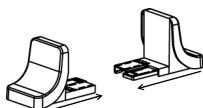

Fig. 3: Tower Feet

2. Place the UPS between feet as shown in Figure 4.

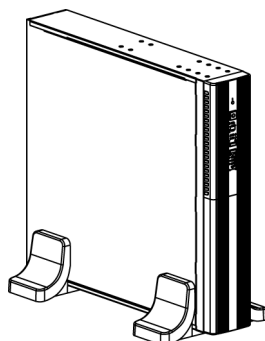

Fig. 4: UPS Tower Set Up

Mounting the Tower UPS Plus One External Battery

1. Assemble the two sets of feet with the spacer provided as shown in Figure 5.

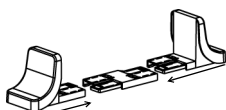

Fig. 5: UPS Feet with Spacer

2. Place feet under UPS and external battery, see Figure 6.

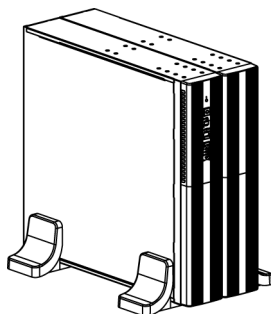

Fig. 6: UPS Tower with Battery Set Up

3. Secure UPS and battery with bracket and screws provided.

Cord Retention Bracket (for models with IEC receptacles)

UPS models that utilize IEC inlets and receptacles have an included accessory that may be installed to help secure the input and output cords in place.

To install the cord retention bracket:

1. Remove the four screws from the right side of the rear of the UPS
2. From the top, open cord retainer.
3. Reinstall screws in the rear of the UPS.
4. Secure each IEC cord using supplied tie wraps. Thread one end of tie wrap through the hole in the cord retainer and around IEC cord. Secure to other end of the tie wrap.

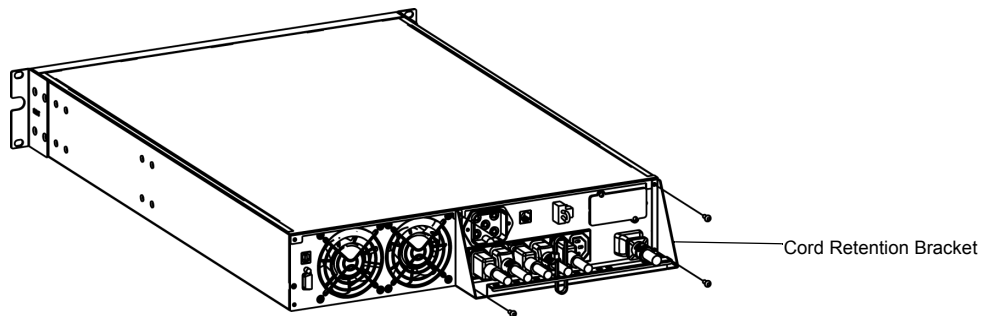

Fig. 7: Cord Retention Bracket

Electrical preparations



WARNING: Before connecting any input wiring to the UPS, take precautions to insure that all circuits being used are the proper voltage and current required for the UPS. If this UPS is not used with the supplied power cord, care must be taken to use properly rated cords (see “Appendix A: Features and Specifications” on page 22) which comply with all regional and local codes.



WARNING: UPS output receptacles are energized when the front panel power switch is in the “ON” position (green LED is illuminated).



WARNING: Electrical shock hazard: Even when the UPS is disconnected from the mains, hazardous voltages may still exist at the output receptacles of the UPS. The UPS receives power from more than one source – AC input and DC input from batteries. All input sources (AC and DC) must, therefore, be disconnected before carrying out maintenance work inside the UPS.

Connections

Battery Connections



WARNING: Before connecting a battery pack to the UPS, the circuit breaker of the battery pack must be switched to “OFF.” After electrical connection with the UPS is established, the breaker must be switched to “ON.”

NOTE: Each Battery Pack contains two battery connectors. The first battery pack is connected to the UPS using the cable supplied with the pack. Each additional extension battery pack is connected by attaching its cable to the previous pack

If additional battery cabinets (up to 4) are to be used, they should be connected prior to connecting the UPS to the input power. To connect external battery cabinets, follow the steps below.

1. Set the circuit breaker on each battery cabinet to the “OFF” position.
2. Connect battery plug at the end of the cable attached to the battery cabinet closest to UPS to the battery receptacle on the rear of the UPS.
3. Connect the battery plug at end of the cable from the next battery cabinet to the battery receptacle on the battery cabinet plugged into UPS.
4. Continue “daisy-chaining” the batteries until all are connected.

5. Connect the battery counter cable between the UPS and the battery cabinet closest to UPS.
6. Set the circuit breakers on each battery cabinet to “ON” position.

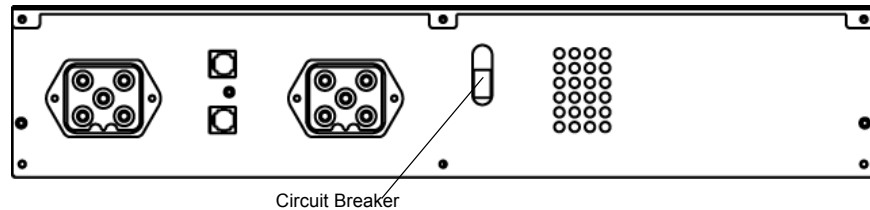

Fig. 8: Battery Circuit Breaker

Power Connections

After all external batteries are connected, make the necessary input and output power connections by following the steps below.

1. Connect the input power cord to the AC outlet

NOTE: The batteries will immediately begin charging upon availability of input power.

2. Connect the load to the UPS.

It is suggested that the highest priority equipment be attached to the main outlets and that lower priority loads be attached to the two programmable outlets.

NOTE: With the use of the ManageUPS[®] network adaptor, the programmable outlets can be set to have a delayed start-up or a pre-scheduled shut-down during battery operation in order to conserve battery power for the highest priority loads.

3. If using a UPS with IEC receptacles and inlets, cords may be secured by using the cord retainer and supplied tie wraps, see Figure 7.
4. After all connections are made, follow the instructions in the section titled “UPS Start-up & Shutdown” on page 14 to start your UPS and external battery.

Theory of Operation



ATTENTION: This UPS is supplied with standard power cords and receptacles suitable for its use in your area of operation. It may be installed and operated by non-technical personnel.

UPS Mode

In use, the UPS is connected between AC input power and the load. The operation of this UPS is based on the on-line principle in which the input AC power is first converted to DC, and secondarily converted back to a sine wave of a fixed frequency and voltage to supply controlled power to the load. This UPS topology is used to isolate the critical load (e.g. servers, switches, routers, etc.) from a variety of power line problems, including the total loss of input AC power.

Battery Mode

In the event of a mains failure, the maintenance-free batteries will continue to provide an uninterrupted supply of energy to the load. In practice, most mains failures are of relatively short duration. Therefore, the energy stored in the UPS’s batteries is, in most cases, sufficient to ensure continuous operation of the connected systems until the mains power is reestablished. In the event of a long lasting mains failure, the UPS can be utilized with shutdown software to enable a controlled shutdown of connected systems.

The most reliable method for determining the estimated battery runtime is the application of MopUPS software or a ManageUPS network card. With this software, the estimated remaining battery capacity is indicated before and during an AC power failure. These products also allow for automated shutdown procedures that can shut down the attached devices after safely closing open application programs and the operating system. After return of the mains voltage, the UPS automatically restores power to the connected equipment.

Bypass Mode

In the event of a brief overload on the UPS or internal UPS failure, the load is immediately supplied directly from the mains via an automatic internal bypass. As soon as normal status is reestablished, an automatic switch over to inverter operation is performed.

- < 110% warning
- 110% - 130%: 12 seconds, switches to bypass
- >130% - 1.5 seconds, switches to bypass

Contact technical service for further details

Front Panel Display and Control

The front panel display contains a series of switches and indicator LED's that provide the operator with the current status of the UPS, and the ability to change UPS operational mode.

- Main UPS ON/OFF switch
- A simplified block diagram of the UPS shows the current operational mode of the UPS (i.e. on-line, on-battery, or on-bypass.)
- Two LED indicators show the current status (ON or OFF) of the controllable receptacle groups 1 and 2.
- Four additional LEDs provide error status, UPS load percentage or battery charge percentage depending on if the associated front panel button is pressed.

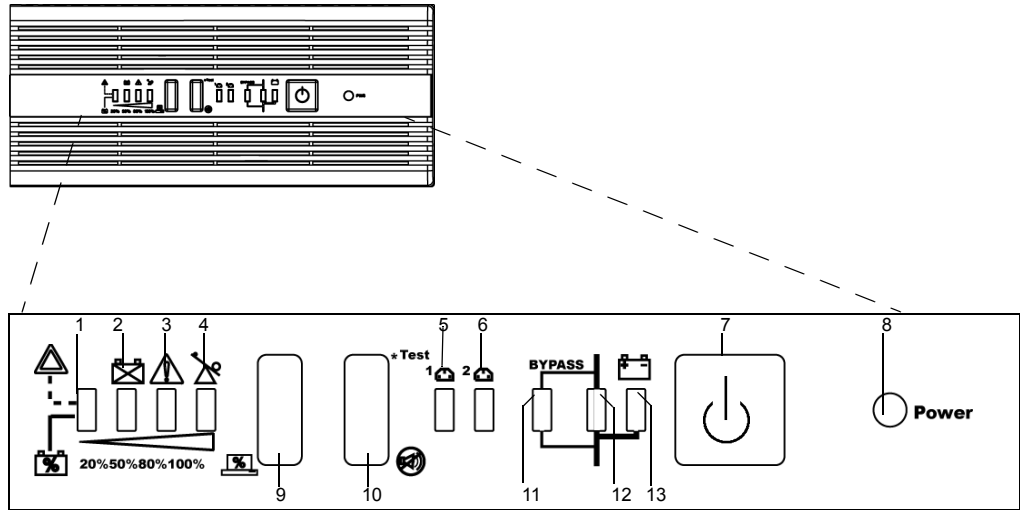

Fig. 9: Front Panel Display

- | | |
|---|---|
| 1. Site Wiring Fault LED | 8. ON LED |
| 2. Battery Fault LED | 9. Display Selector(Battery Charge/UPS Load% (on LED's 1-4) |
| 3. UPS Fault LED | 10. LED Test/Alarm Reset |
| 4. UPS Overload LED | 11. Operation in BYPASS Mode |
| 5. Controllable Receptacle Group 1 On / Off | 12. Operation in ON-LINE Mode |
| 6. Controllable Receptacle Group 2 On / Off | 13. Output Supplied by Battery |
| 7. Standby (ON / OFF Switch) | |

System Indicators

Table 3 System Indicator

Condition	Audible	Visual
UPS Off/unplugged	None	None
UPS Off/plugged in	None	LEDs #1, #2, #3, #4 are on to show battery capacity.
Start-up On - AC Power	One and two beeps	After start-up checks, #12 turns on.
Start-up On - Battery	One and five beeps	After start-up checks, #13 turns on.
On-Line	NA	On-Line LED #12 is on.
On-Bypass	NA	On-Bypass LED #11 is on.
Transfer to Battery	Three beeps	On-Line LED #12 turns off; On-Battery LED #13 turns on.
Low Battery	Beep every 3 seconds	#13 flashes every three seconds.
End of Battery	Constant sound	#13 is on constant
Overload < 110%	Beeps every second	None
Overload >110%	Beeps every second	Overload indicator #4 flashes UPS will shutdown after a delay.
UPS Fault	Constant sound	UPS Fault indicator #3 flashes

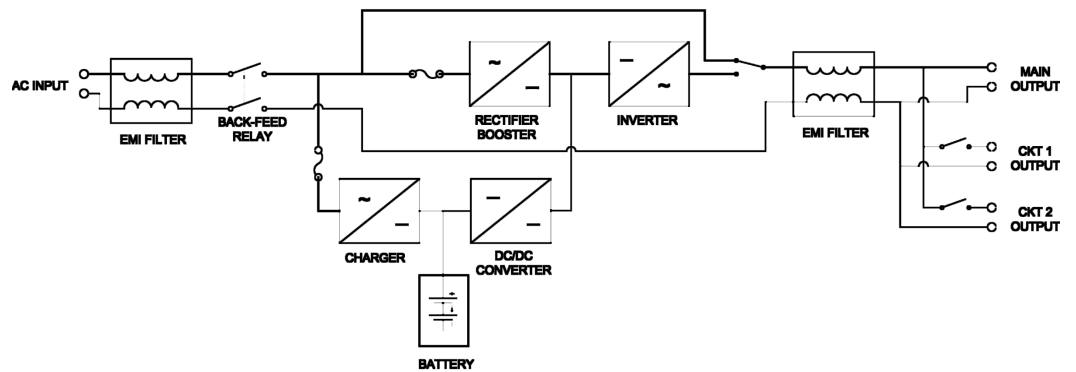

Fig. 10: Block Diagram

Rear Panel

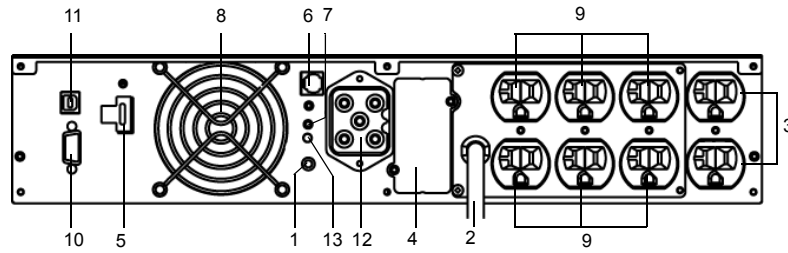

Fig. 11: Rear Panel for 700 VA, 1000 VA, 1500VA (120 Volt) Models

- | | |
|--|---------------------------------------|
| 1. Environmental Reference Ground | 8. Fan |
| 2. Input Power Connections | 9. Output Receptacles |
| 3. Controllable Receptacles | 10. Interface COM3 (RS232) |
| 4. Slot Interface COM | 11. USB Interface |
| 5. RPO Connection | 12. External Battery Power Receptacle |
| 6. Battery Counter Connector | 13. Site Wiring Fault Indicator |
| 7. Push Button for Phase/Neutral Reversal Test | |

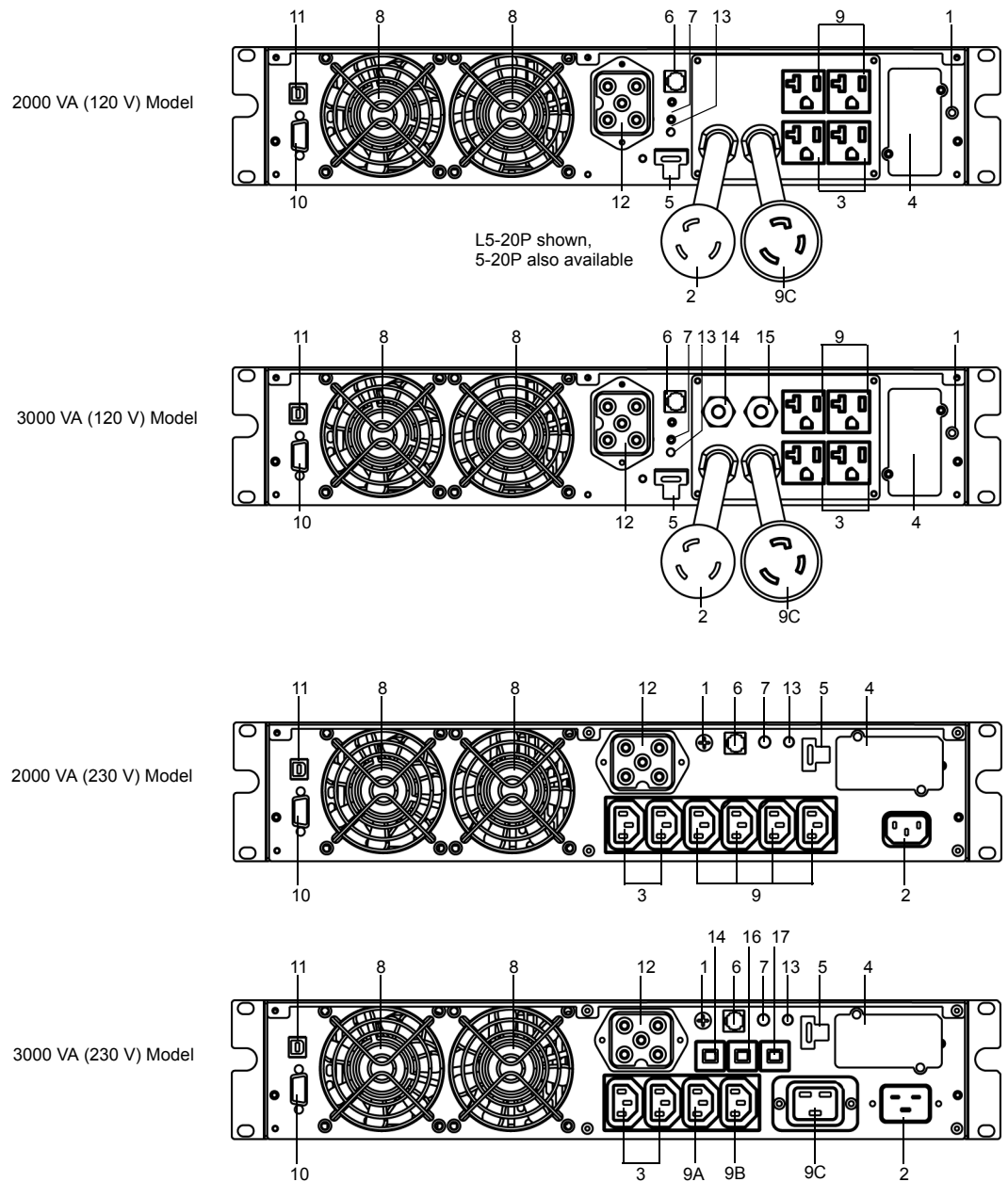

Fig. 12: Rear Panel for 2000 VA and 3000 VA

- | | |
|--|--|
| 1. Environmental Reference Ground | 9. Output Receptacles (9C full nameplate rated output) |
| 2. Input Power Connections (for 2000 VA [120 V] model L5-20P shown, 5-20P available) | 10. Interface COM3 |
| 3. Controllable Receptacles | 11. USB Interface |
| 4. Slot Interface COM | 12. External Battery Power Receptacle |
| 5. RPO Connection | 13. Site Wiring Fault Indicator |
| 6. Battery Counter Connector | 14. Circuit Breaker for 3 Only (3000 VA, 120V only) |
| 7. Push Button for Phase/Neutral Reversal Test | 15. Circuit Breaker for 9 Only (3000 VA, 120V only) |
| 8. Fans | 16. Circuit Breaker for 9A (3000 VA, 230V only) |
| | 17. Circuit Breaker for 9B (3000 VA, 230V only) |

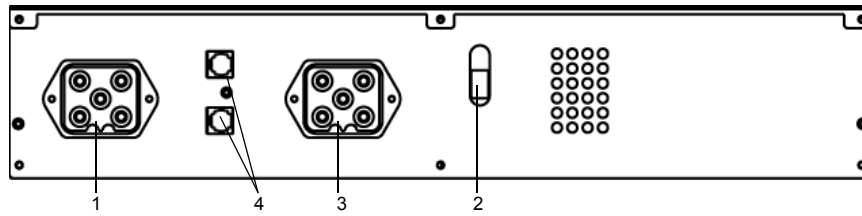

Fig. 13: Rear Panel External Battery Pack

- 1. Battery Power Receptacle (input from UPS)
- 2. Battery Circuit Breaker
- 3. Battery Power Receptacle (output to additional battery)
- 4. Battery Counter Connector

UPS Start-up & Shutdown



ATTENTION: This UPS is supplied with standard power cords and receptacles suitable for its use in your area of operation. It may be installed and operated by non-technical personnel.

Initial UPS Start-up Procedure



ATTENTION: When the UPS is started for the first time, AC Power must be present.

When using the UPS for the first time, confirm AC power is present and press .

The UPS will respond first with a brief beep followed by a brief illumination of all LED indicators. The UPS will then sound two brief beeps, and turn on the ON-LINE LED indicating that the unit is now in ON-LINE mode.

Power should now be available to the connected equipment.

Normal UPS Start-up Procedure

Press the button.

The UPS will respond first with a brief beep followed by a brief illumination of all LED indicators.

If AC power is present, the UPS will sound two brief beeps, and turn on the ON-LINE LED indicating that the unit is now in ON-LINE mode.

If AC power is not present, the UPS will sound five brief beeps and turn on the ON-BATTERY LED indicating that the unit is now providing output power from the battery.



ATTENTION: If the overload indicator is on, or the “LOAD” indicator is beyond 100%, there are too many devices connected to the UPS. If only one device is connected to the UPS and the overload indicator is on, then the load’s power demand exceeds the rating of the UPS, and a UPS with a higher power rating must be used

NOTE: If the UPS does not respond as above, please see “Troubleshooting” on page 20.

Manual Bypass Procedure

To place the UPS into bypass mode, press and hold buttons 9 and 10 for 5 seconds (see figure 9 on page 10). The UPS will switch to bypass mode and the BYPASS LED will illuminate.

UPS Shutdown Procedure

Press the button. The UPS will turn off all outputs, and shutdown.

To restart UPS see “Normal UPS Start-up Procedure” on page 14.



WARNING: This equipment receives power from more than one source. The output receptacles may have voltage even when the unit is turned off.

Remote Power Off (RPO)

The external connection to the RPO circuit is located next to the 9-pin SUB-D (interface RS232) connector in the upper rear of the unit. If the circuit between the two RPO connector pins is “opened,” the output of the UPS is immediately switched off. To restart the UPS, the procedures outlined in the “UPS Start-up Procedure” must be followed. The RPO circuit may be extended by connecting the “normally closed” switches in series between the RPO connector pins. Activating (opening) any of the series switches will cause the UPS to shut off its output.

Maintenance

Cleaning

Do not use scouring powder or plastic-dissolving solutions to clean the UPS.

Do not allow liquid to get inside the UPS.

Make sure that the air vents on the UPS are not obstructed. Remove dust from the air vents with a vacuum cleaner.

Clean the outside of the UPS housing by wiping with a dry or slightly damp cloth.

UPS Storage

For extended storage at ambient temperatures < 77°F (25°C), the batteries should be charged for five hours once every four months. At higher storage temperatures it is advised that this period be reduced to two months.

To charge the batteries, connect the UPS to an appropriate power source and allow the batteries to charge for about five hours. After charging, note the date recharging was performed on the UPS packaging.

Battery Testing

The UPS does not require maintenance by the user; however, the battery should be checked periodically.

The UPS will automatically perform a battery self-test once a month. If a problem is discovered, the Battery Fault LED will illuminate. See “Troubleshooting” on page 20 if a problem is found.

The frequency of testing can be changed through MopUPS Professional. Select battery self-test to be performed monthly, weekly, or none.

Replacing Batteries



ATTENTION: The load attached to the UPS will not be protected against loss of input power during this procedure.

Replacing the UPS internal batteries



WARNING:

- Servicing of batteries should be performed or supervised by personnel knowledgeable about batteries and the required precautions.
- The batteries installed in the UPS and in the external battery cabinets contain electrolyte. Under normal conditions the containers are dry. A damaged battery may leak electrolyte that can be dangerous in contact with the skin and cause irritation to the eyes. Should this happen, wash the affected part with copious amounts of water and seek immediate medical attention.
- When replacing batteries, replace with the same type and number of batteries or battery packs.
- Do not dispose of batteries in a fire. The batteries may explode.
- Do not open or damage the battery cases. Released electrolyte is harmful to the skin and eyes and may be toxic.
- A battery can present a risk of electrical shock and high short-circuit current. The following precautions should be observed when working on batteries:
 - Remove watches, rings or other metal objects
 - Use tools with insulated handles
 - Wear rubber gloves and boots
 - Do not lay tools or metal parts on top of batteries



Do not discard waste electrical or electronic equipment (WEEE) in the trash. For proper disposal, contact your local recycling/reuse or hazardous waste center.

The UPS does not require maintenance by the user, however, battery maintenance is recommended in accordance with IEEE Recommended Practice for Maintenance, Testing and Replacement of Valve-Regulated Lead-Acid (VRLA) Batteries for Stationary Applications (IEEE Std 1188-1996). When the batteries expire, trained battery service personnel must replace them. A certified disposal/recycling company should carry out disposal/recycling of the UPS and/or batteries. Exhausted rechargeable batteries are classified as “harmful toxic waste” and as such the law demands that they be disposed of/ recycled by an authorized recycling center.

The manufacturer's service center is fully equipped to deal with such batteries, in accordance with the law and with the greatest respect for the environment. Contact Technical Support to arrange for maintenance and/or battery replacement.

The typical battery life cycle is 3 to 5 years, at an ambient temperature of 77°F (25°C), however battery life is also dependent on the frequency and duration of mains failures or battery discharge cycles.

The BATTERY TEST (see section titled "Battery Test") should be carried out periodically (6 to 12 months) in order to ascertain the general condition of the batteries.

To replace internal batteries:

1. Place the UPS manually in bypass mode, see "Manual Bypass Procedure" on page 14.
2. On the left side of the front cover, locate the indentation.
3. Place fingers of left hand into the indentation, and pull forward until the left side of the front cover "snaps" out of position.
4. Remove the left side of the front cover and place it in a safe place.
- 5a. **On 700 VA, 1000 VA, and 1500 VA:** Remove one screw on the right side of the battery retention plate that is now exposed on the front left side of the UPS.

Disconnect battery connectors.

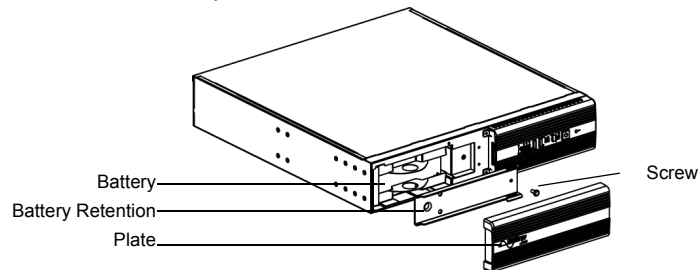

Fig. 14: Removing Front Cover and Battery Retention Plate

- 5b. **On 2000 VA and 3000 VA:** Disconnect battery connectors.

Remove one screw on the right side of the battery retention plate that is now exposed on the front left side of the UPS.



ATTENTION: Battery pack is heavy. Use two hands when removing pack from unit

6. Slide out battery pack.

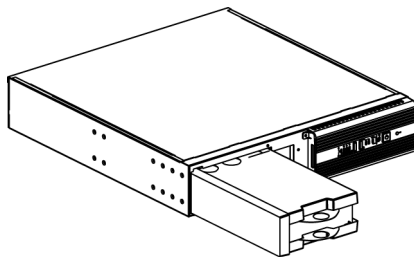

Fig. 15: Removing Battery

7. Slide in replacement battery pack.
- 8a. **On 700 VA, 1000 VA, and 1500 VA:** Re-connect the battery connectors.
Replace metal battery retention plate with screw.
- 8b. **On 2000 VA and 3000 VA:** Replace the metal battery retention plate with screw.
Re-connect battery connectors.
9. Align left plastic front.
10. Snap battery front cover into place.
11. Carefully pack used battery pack and send to authorized recycle center.

Battery Disposal

The typical battery life cycle is 3 to 5 years, at an ambient temperature of 25 °C, but is also dependent on the frequency and duration of mains failures.

Once the battery has reached the end of its useful life, follow the procedure for battery replacement, see “Replacing Batteries” on page 15.

After the batteries are replaced, a certified disposal/recycling company should carry out disposal/recycling of the used batteries.

Exhausted rechargeable batteries are classified as “harmful toxic waste” and as such the law demands that they be disposed of/recycled by an authorized recycling center.

The manufacturer’s service center is fully equipped to deal with such batteries, in accordance with the law and with the greatest respect for the environment. Contact Technical Support to arrange for maintenance and/or battery replacement. See page 1 for contact information.

Interfaces

The UPSs are equipped with a serial interface COM 3, USB, and an interface slot COM.

These interfaces can be used for:

- Direct communication between UPS and a workstation/server.
- Integration of the UPS as client into a network with centralized monitoring via a ManageUPSNET SNMP adapter in the slot COM.
- Transfer of operational states to external alarm systems via voltage-free contacts: with interface card SIC in the slot COM.

The necessary communication software packages and interface cables are available as options.

Serial interface COM 3

The 9-pole SUB-D connector (pin contacts) contains RS232 compatible signals.

NOTE: The interface COM RS232 is electrically isolated from primary UPS circuits.

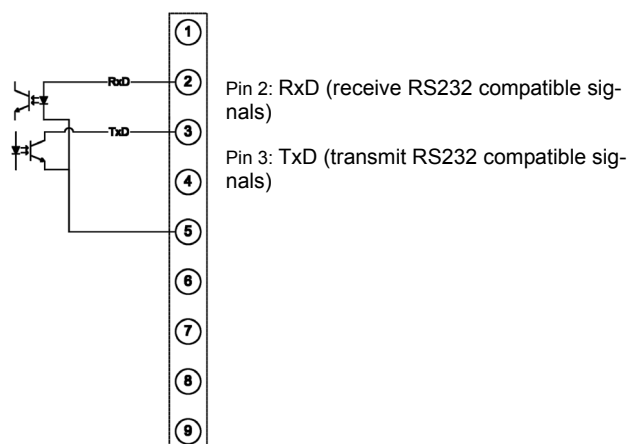

Fig. 16: Serial Interface COM3

Interface Slot COM

The interface slot COM can be fitted with various optional interface cards. Interface cards include:

- SNMP-adapter (ManageUPSNET) for connecting the device to a network
- isolated contacts card

Refer to the installation guide supplied with the optional interface card.

Communications

With a communications cable and MopUPS® Professional installed, MopUPS Professional can exchange data with the UPS. This power management software polls the UPS for detailed information on the status of the power environment. If a power emergency occurs, the software initiates an orderly shutdown of the

equipment. The interface ports will send On Battery and Low Battery signals to the host computer. The interface ports will also accept a shutdown inverter signal to conserve battery life.

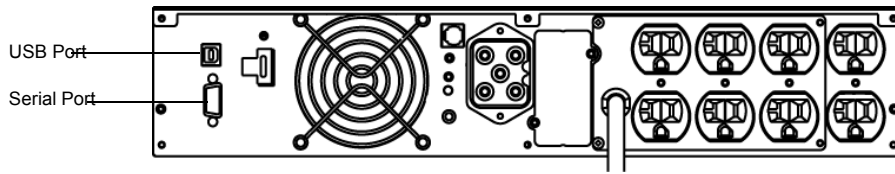

fig. 17: UPS Communications Ports

Installing MopUPS Professional

To establish communications between the UPS and a computer:

1. Connect the computer to the UPS communications port using the supplied USB communications cable.

NOTE: If a serial connection is required, contact the factory to purchase optional serial cable (part number CA-2B10S-03).

NOTE: RS232 and USB communications ports cannot be used simultaneously.

2. Insert the supplied software CD into the computer's CD-ROM drive.
3. Once the CD is inserted into the drive, an installation wizard will appear. Follow the installation instruction from the wizard.

Once MopUPS Professional is installed and launched, the user manual can be accessed by clicking on the Help button. If further assistance is needed, contact Technical Service at 800-327-8801, option 3 or email: us.service@chloridepower.com.

Optional Isolated Contacts Card

Below are the descriptions of the interface signals for the isolated contacts card that may be installed into the COM slot. This optional card provides potential-free signaling contacts and a shutdown input.

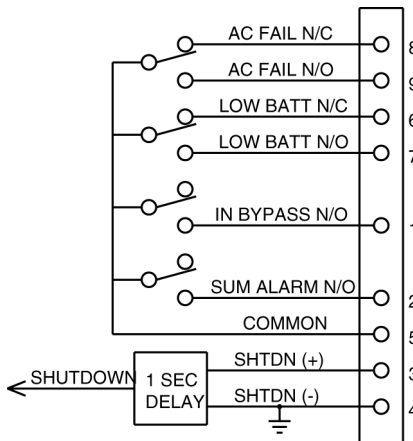

Fig. 18: Isolated Contacts Card Interface Signals

INV SHUTDOWN

This input (pin 3) is enabled with a high signal (+5 V to +12 V with respect to pin 4 (0 V)) and when enabled, switches off the UPS after a mains failure has occurred. After the mains have been reestablished, the UPS starts again independent of this signal status. This input must be high for one (1) second before shut off will occur.

AC FAIL

This output provides an N/O (Normally Open) contact between pins 9 and 5, and an N/C (Normally Closed) contact between pins 8 and 5. The 9-5 contact closes when the mains voltage fails at the UPS input or when the mains voltage falls below the lower limit for a minimum of 10 seconds. This contact opens approximately 850 ms after the mains have been reestablished. The 8-5 contact provides a mirror function, opening when the mains voltage fails and closing when main power returns

LOW BATT

This output provides a N/O contact between pins 6 and 5 and an N/C contact between pins 7 and 5. The 6-5 contact closes when the battery has been depleted to the point that it can only supply current for approximately three (3) more minutes at nominal load. The 7-5 contact provides a mirror function opening when the battery is low.

BYPASS ACTIVE

This output provides an N/O contact between pins 1 and 5. The 1-5 contact closes after switching to the bypass mode. In the bypass mode, energy to the output of the UPS is being supplied by the mains power and not through the inverter.

SUM ALARM

This output provides an N/O contact between pins 2 and 5. The 2-5 contact closes when one of the alarms “AC FAIL,” “LOW BATT” or “BYPASS ACTIVE” is active or when the indication “ALARM” at the front-panel is on.

Troubleshooting

If problems should occur in spite of the high reliability of this device, please check the following points before contacting Technical Support:

- Is the mains voltage present at the UPS input?
- Is the input fuse blown or have circuit breakers tripped?

When contacting Technical Support, please have the following information ready:

- UPS information
 - model number
 - part number
 - serial number as per nameplate
- An exact description of the problem (what loads are being operated, does the problem occur regularly or sporadically, etc.) including any fault message description(s).

Table 4 Troubleshooting

Problem	Possible cause	Corrective Actions
Overload LED blinks/buzzer beeps once per second. UPS is in bypass.	<ul style="list-style-type: none"> • UPS is overloaded. • Overload is too large or long. • (Unit on AC Power) 	<ul style="list-style-type: none"> • Check the power drawn by the equipment and disconnect any short circuited or non-priority devices.
Overload LED blinks/buzzer beeps continuously. Load is dropped	<ul style="list-style-type: none"> • UPS is overloaded. • Overload is too large or long. • (Unit on Battery Power) 	<ul style="list-style-type: none"> • Check the power drawn by the equipment and disconnect any short circuited or non-priority devices. • Restart the UPS.
Battery LED blinks/ buzzer beeps.	<ul style="list-style-type: none"> • A battery fault was detected during the automatic battery test. 	<ul style="list-style-type: none"> • Check that battery connector is properly seated. • Replace the battery module.
Battery LED blinks/ buzzer sounds long beep about once every hour.	<ul style="list-style-type: none"> • The battery is at end of life; runtime on battery is compromised. 	<ul style="list-style-type: none"> • Reset alarm by pressing LED test/ Alarm Reset buttons on the front of unit • Replace the battery module.
Site wiring fault LED blinks. Red LED behind UPS on. Buzzer sounds continuously.	<ul style="list-style-type: none"> • Phase reversal (line and neutral) has been detected on input power. 	<ul style="list-style-type: none"> • If one side of input power is to be a grounded neutral (typically 120 volts systems or 230 volt TN systems) have electrician correct reversal in receptacle or power system. • If neither side of input power is to be a grounded neutral (typically phase to phase 208 volts, or 230 volt TX systems) disable function by pressing the push-button on the rear of the UPS between fan and battery connector for five seconds. Note: Disabling this function must occur within 30 minutes of initial power up of unit.
Fault LED blinks. Buzzer sounds continuously.	<ul style="list-style-type: none"> • UPS has detected a fault. 	<ul style="list-style-type: none"> • Call technical support.

Warranty

ONEAC products are warranted to be free from defects in materials and workmanship for two years. This warranty is limited to repairing or replacing, at ONEAC's option, any defective component, circuit board, or module contained within the product only when it is returned with an ONEAC Return Material Authorization (RMA) number to ONEAC or to an ONEAC-designated repair facility. In all cases, the customer is responsible for shipping charges to and from ONEAC or the ONEAC-designated repair facility.

Batteries

Certain modules or peripherals included with the product, but not manufactured by ONEAC, including but not limited to batteries or battery enclosures, are warranted for two years or the extent of the manufacturer's warranty, whichever is longer.

Limitations of Warranty

This limited warranty does not cover any losses or damage resulting from shipment to or from the customer, or from improper installation, inappropriate environment, abuse, modifications, adjustments, or unauthorized repair.

For full details of the warranty, see ONEAC Warranty, Policy and Procedures (part number 955-053).

Exclusive Remedies

Except as set forth herein and except as to title, there are no warranties, express or implied, or any affirmations of fact or promises by ONEAC for the products, their merchantability, or fitness for any particular purpose. In no event shall ONEAC be liable for lost profits, goodwill or any other special or consequential damages.

Return Procedure

To return a UPS, contact ONEAC Technical Support (page 1) for a Return Material Authorization (RMA) number. This number must be marked on the shipping carton and packing slip of the unit returned. The customer is responsible for repair charges for damages incurred in shipment that result from inadequate or improper packing of the product.

Appendix A: Features and Specifications

Your ONEAC Sinergy S IISeries UPS features on-line double conversion. This provides the highest level of protection from power line disturbances available.

- Two-year warranty on power control systems
- Two-year warranty on batteries
- Scalable power and runtimes
- Hot-swappable, user replaceable batteries
- Integrated manual and automatic bypass
- Comprehensive front panel control/indicators
- Remote Power Off (RPO)

**Physical and
Electrical
Specifications**

Nominal input voltage: XAU models (low voltage): 120 V (factory default)
100, 127 V (user selectable with SNMP)
XHU models (high voltage): 208 V (factory default)
200, 208, 220, 230, 240 (user selectable w SNMP)

Available output voltage: XAU models (low voltage): 120 V (factory default)
100, 127 V (user selectable with SNMP)
XHU models (high voltage): 208 V (factory default)
200, 208, 220, 230, 240 (user selectable w SNMP)

Principle of operation: On-line, double conversion

Surge voltage withstand capability: ANSI/IEEE C62.41 Cat. A & B

Crest factor: 3:1

Recharge time to 90% available capacity: 5 - 8 hours

Total harmonic disortion (linear load): < 4%

Automatic bypass: integrated

Alarms: Mains power, low battery, overload, on bypass

Cooling: Fans

Appendix A: Features and Specifications

Specifications

UPS Model	S0K7XAU	S1K0XAU	S1K5XAU	S2K0XAU	S3K0XAU	S2K0XHU	S3K0XHU
Part number	S0K7XAU	S1K0XAU	S1K5XAU	S2K0XAU	S3K0XAU	S2K0XHU	S3K0XHU
Maximum load (VA/W)	700 VA/490 W	1000 VA/700 W	1500 VA/1050 W	2000VA/1400 W	3000 VA/2100 W	2000 VA/1400 W	3000 VA/2100 W
Acceptable input voltage range (VAC)	80-142					160-280	
Nominal input voltages (VAC)	120 (factory default) 100, 127 (selectable)					208 (factory default) 200, 208, 220, 230, 240 (selectable)	
Input frequency	50/60 Hz ±5%, auto-select						
Nominal output voltages (V)	120 (factory default) 100, 127 (selectable)					208 (factory default) 200, 208, 220, 230, 240 (selectable)	
Output current @ 120 V (A) @ 208 V (A)	5.8 NA	8.3 NA	12.5 NA	16.7 NA	25 NA	NA 9.6	NA 14
Output frequency	50/60 Hz ±0.5%						
Frequency tolerance, normal operation	output frequency is synchronized with the maximum frequency						
Output waveform	Sinusoidal						
Overload capacity	< 110% warning 110% - 130%: 12 seconds, switches to bypass >130% - 1.5 seconds, switches to bypass contact technical service for further details						
Input connection	5-15P			L5-20P or 5-20P	L5-30P	IEC320 to L6-20P	IEC320 to L6-30P
Output connection	(8) 5-15R			(4) 5-20R & (1) L5-20R	(4) 5-20R & (1) L5-30R	IEC (contact factory for IEC to NEMA adapters)	
Port standard	(1) serial, (1) USB						
Comm slot	1 slot for SNMP/Web Interface						
Internal battery	(3) VRLA, 12 V, 7 AH		(3) VRLA, 12 V, 9 AH	(6) VRLA 12 V, 7 AH	(6) VRLA 12 V, 9 AH	(6) VRLA 12 V, 7 AH	(6) VRLA 12 V, 9 AH
Battery type	sealed, maintenance-free lead acid, VRLA						
Battery test	Automatic, once per month (adjustable through UPS management software supplied)						
Battery management	EXB auto recognition, automatic runtime adjustment, protection against deep discharge						
UPS dimensions - HxWxD - in. (cm)	3.4 x 17.2 x 19.2 (8.64 x 43.7 x 48.7)			3.4 x 17.2 x 26.3 (8.64 x 43.7 x 66.8)			
UPS ship weight - lbs(kg)	56 (25)	60 (27)	60 (27)	85(39)	86 (39)	85 (39)	86 (39)
External battery (maximum 4 per UPS)	SBP1K5-2; (6) 12 V, 7 AH			SBP3K0-2; (6) 12 V, 9 AH			
External battery dimensions - HxWxD	3.4 x 17.2 x 19.2 (8.64 x 43.7 x 48.7)			3.4 x 17.2 x 26.3 (8.64 x 43.7 x 66.8)			
External battery ship weight - lbs (kg)	64 (29)			107 (49)			
Interfaces COM A	9 pin SUB-D pin contacts						
Operating temperature	32°F to 104°F (0°C to 40°C) recommended 50°F to 77°F (10°C to 25°C)						
Storage temperature	5°F to 120°F (-15°C to 50°C) recommended 50°F to 77°F (10°C to 25°C)						
Relative humidity	20% to 90%, non-condensing						
Heat dissipation (max.) (BTU/hr)	275	390	584	1004	1158	810	1158
EMC	FCC part 15, class B, EN 61000-6-1, EN 61000-602, EN 55024			FCC part 15, class A, EN 61000-6-1, EN 61000-602, EN 55024			
ROHS	yes			yes			

Table 5. Typical Runtimes

	Internal Battery	Internal Battery Plus 1 Ext Battery	Internal Battery Plus 2Ext Battery	Internal Battery Plus 3Ext Battery	Internal Battery Plus 4Ext Battery
S0K7XAU half load/full load (min)	27/11	110/50	228/93	328/148	450/200
S1K0XAU half load/full load (min)	19/7	76/32	152/59	228/93	323/126
S1K5XAU half load/full load (min)	13/5	52/19	103/33	157/54	218/74
S2K0XAU half load/full load (min)	16/8	86/44	171/61	285/90	404/135
S3K0XAU half load/full load (min)	14/6	57/23	114/58	171/90	247/124
S2K0XHU half load/full load (min)	16/8	86/44	171/61	285/90	404/135
S3K0XHU half load/full load (min)	14/6	57/23	114/58	171/90	247/124

Table 6 Derating factor for use above 1000 m

Altitude (meters)	Derating factor (output VA or Watts)
1000	1.0
1500	0.95
2000	0.91
2500	0.86
3000	0.82
4000	0.74
4500	0.7
5000	0.67

Chloride North America

27944 North Bradley Road
Libertyville, IL 60048
USA

T: 800 327 8801, 847 816 6000
F: 847 680 5124

www.chloridepower.com/usa

CHLORIDE

www.chloridepower.com/usa

Chloride operates through a worldwide network of Chloride sales and service offices and joint-ventures, with operations across 80 countries including:

Almaty, Kazakhstan	Chicago, USA	Lisbon, Portugal	Paris, France	Singapore
Bangkok, Thailand	Dubai, UAE	Istanbul, Turkey	Pune, India	Southampton, UK
Beijing, China	Erlangen, Germany	Madrid, Spain	Sao Paulo, Brazil	Sydney, Australia
Bologna, Italy	Ho Chi Minh City, Vietnam	Moscow, Russia	Shanghai, China	Warsaw, Poland



Chloride Australia
Ground Floor
16 Giffnock Avenue, North Ryde
NSW 2113
Australia

T: +61 2 9888 1266
F: +61 2 9888 1966

www.chloridepower.com.au

Chloride Middle East
Building 5, Office 104
Dubai Internet City - Dubai
UAE
PO Box 72536

T: +971 4 391 3205
F: +971 4 391 6803

www.chloridepower.com/middle-east

Chloride Brazil
Av. Eng. Alberto de Zagottis, 695
Jurubatuba - São Paulo - SP
CEP: 04675-085 Brazil

T: +55 11 5541 5599
F: +55 11 5541 5599

www.chloridepower.com.br

Chloride Thailand
Panjathani Tower, 20th Floor
127/25 Nonsee Road
Chongnonsee, Yannawa, Bangkok 10120
Thailand

T: +662 296 9800
F: 662 681 0109

www.chloridepower.com/th

Chloride United Kingdom
George Curl Way
Southampton, Hampshire
SO18 2RY
United Kingdom

T: +44 (0) 23 8061 0311
F: +44 (0) 23 8061 0852

www.chloridepower.co.uk

Chloride Italy
Via Fornace, 30
40023 Castel Guelfo (BO)
Italy

T: +39 0542 632 111
F: +39 0542 632 120

www.chloridepower.com/it

CHLD Singapore Pte Ltd
2 Corporation Road
#03-07 Corporation Place
Singapore
618494

T: +65 6481 4776
F: +65 6481 0552

www.chloridepower.com.sg

Chloride Vietnam
Unit 1708, 17th Floor, Gemadep Tower
06 Le Thanh Ton Street, Ben Nghe Ward
District 1, Ho Chi Minh City
Vietnam

T: +84 8 255 6737
F: +84 8 255 6800

www.chloridepower.com/vn

ONEAC and Sinergy are registered trademarks of ONEAC. All trademarks are the property of their respective companies. © 2010 Chloride